

15038

HOUSING Aluminium Die Casting painting black
BEARING Ball or Sleeve
INSULATION RESISTANCE 10 M Ohms min. @ 500 Vdc
OPERATING TEMPERATURE -10 to +60 °C
WEIGHT 625 g
ROHS COMPLIANCE Yes



SIZE

150 x 150 x 38 mm

DIMENSION

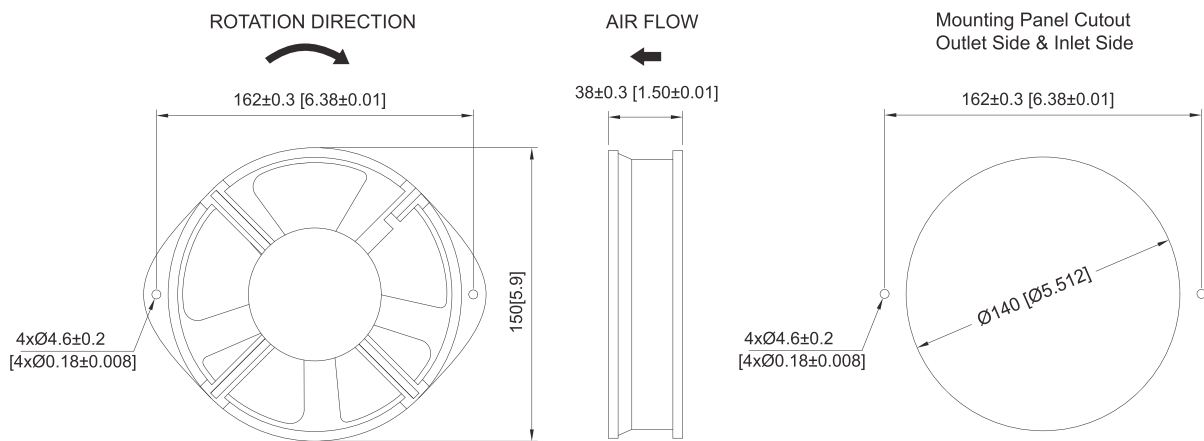

UNIT:mm[inch]

AIR PERFORMANCE

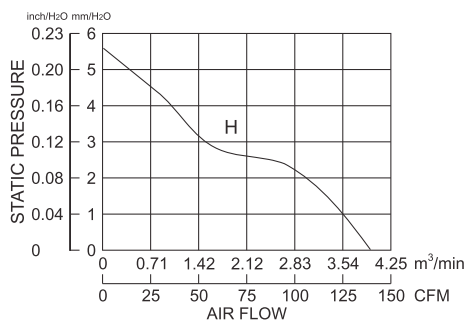

SPECIFICATION

MODEL NO	Rated Voltage	Input Current	Input Power	Speed	Maximum Air Flow	Maximum Air Pressure	Noise
	VDC	Amp	Watt	R.P.M.	CFM / m ³ /min	inchH ₂ O / mmH ₂ O	dB-A
ART1414-15038-12HBC	12	0.75	9	2200	140 / 3.97	0.22 / 5.61	42
ART1415-15038-24HBC	24	0.40	9.6	2200	140 / 3.97	0.22 / 5.61	42
ART1416-15038-48HBC	48	0.23	11	2200	140 / 3.97	0.22 / 5.61	42